

Specifications

MODEL	MECHRON2200	MECHRON2210 (EEC Homologated)	MECHRON2230 (EEC Homologated)	MECHRON2240 (2-Row)	
ENGINE					
Model	3C100LWU				
Type	3Cyl. In-line vertical. Water-cooled 4-cycle diesel engine3Cyl. In-line vertical. Water-cooled 4-cycle diesel engine				
Engine Gross	HP(kW)	22(16.4)			
Displacement	CC	1,007			
Rated Revolution	rpm	2,800			
Fuel Tank Capacity	ℓ	28			
DRIVE TRAIN					
Type	Belt CVT				
Gear Range	Low, High, Neutral, Reverse				
Ground Speed	km/h	0-40			
Brake	Front/Rear Hyd. Dry Caliper Disc				
SUSPENSION					
Front Suspension	Independent, MacPherson Strut type				
Rear Suspension	Independent, Double A-Arm(Wishbone type)				
STEERING					
Type	Rack & Pinion	Hydraulic Power Steering			
DIMENSIONS					
Length	mm	2,852	2,852	3,205	3,725
Width	mm	1,543	1,543	1,543	1,543
Height	mm	1,940	2,032	2,032	1,940
Max Wheel Tread	Front	1,262			
	Rear	1,264			
Wheelbase	mm	1,940	1,940	2,240	2,760
Weight (with ATV Tires)	kg	740	840	882	860
Ground Clearance	mm	305			
Towing Capacity	kg	590			
Payload Capacity	kg	725			
Turning Radius	m	3.7	3.7	3.7	5.4
CARGO BED					
Length x Width x Depth	mm	980 x 1427 x 293	980 x 1427 x 293	1280 x 1427 x 293	980 x 1427 x 293
Towing Capacity	kg	500	500	500	300
TIRE SIZE					
Front	Heavy Duty Worksite	25 x 10 - 12	25 x 10 - 12	25 x 10 - 12	25 x 10 - 12
	Turf	25 x 10 - 12	25 x 10 - 12	25 x 10 - 12	25 x 10 - 12
	ATV	25 x 10 - 12	25 x 10 - 12	25 x 10 - 12	25 x 10 - 12
Rear	Heavy Duty Worksite	25 x 11 - 12	25 x 11 - 12	25 x 10 - 12	25 x 10 - 12
	Turf	25 x 11 - 12	25 x 11 - 12	25 x 10 - 12	25 x 10 - 12
	ATV	25 x 11 - 12	25 x 11 - 12	25 x 10 - 12	25 x 10 - 12
Seat Capacity	3 Seat Bench	1 Sus. Seat Bench 2 Seat Bench	1 Sus. Seat Bench 2 Seat Bench	2 Rows (3 Seat Bench Type)	
Front Guard	Std.				
Dump Box Actuation	Manual				
Body Color(Hood/Cargo)	Orange/Black				
Hydraulic Bed Lift	Opt.				
Hydraulic Utility Valve	Opt.				
Speedometer	Std.				

※ Note: The specifications are subject to change without notice.



Daedong Kioti Europe B.V
Stationsweg 36, 3214 VK Zuidland,
Netherlands
Tel. 31-181-458851
Fax. 31-181-452114



Optional Equipment

- **CANOPY/WINDSHIELD**
Sun Canopy Kit
Wind Wiper Kit
WindShield Kit(Safety Glass, PC)
- **HITCH**
Front Hitch Receiver Kit(EEC)
- **HYDRAULICS**
Hydraulic Dumping Kit
Remote Hydraulic Kit
Hand Throttle Kit
- **PROTECTION**
Skid Plate Kit
Rear Screen Kit
Suspension Dust Guard Kit (CV Guard Kit)
Soft Cabin Kit(Black, Camo)
- **ACCESSORIES**
Safety Light Kit(Tail, Brake, Turn signal, Hazard Switch, Horn)
Fog Lamp Kit
Working Lamp Kit
Headrest Kit
Side View Mirror Kit(EEC)
License Plate Kit
Parking Brake Buzzer Kit
Winch Kit
Deck Extension Kit
Alarm, SYS back-up kit
Swing-Drawbar kit(EEC)
Oil-Cooler Kit

The Ultimate Transport Vehicle

MECHRON

2200 / 2210 / 2230 / 2240



Kioti Tractor / Daedong Ind. Co., Ltd. / EU_Mechron2240_15.04



Part Number LIT-UTV-ALL1



*Where Work and play
come Together*



The MECHRON

Whether you need a worker on the farm or a way into the woods, the **KIOTI MECHRON 4X4** Utility Vehicle gets all your jobs done. With 4-wheel, fully independent, rear dual A-arm suspension and front MacPherson type suspension, the wide track offers increased stability and an exceptionally smooth ride on even rough terrain. The tight turning radius and rear anti-sway bar provides superb cornering and handling. Wherever work or play takes you, you'll have the ultimate 4-wheel drive performance.



Translating Power into Performance

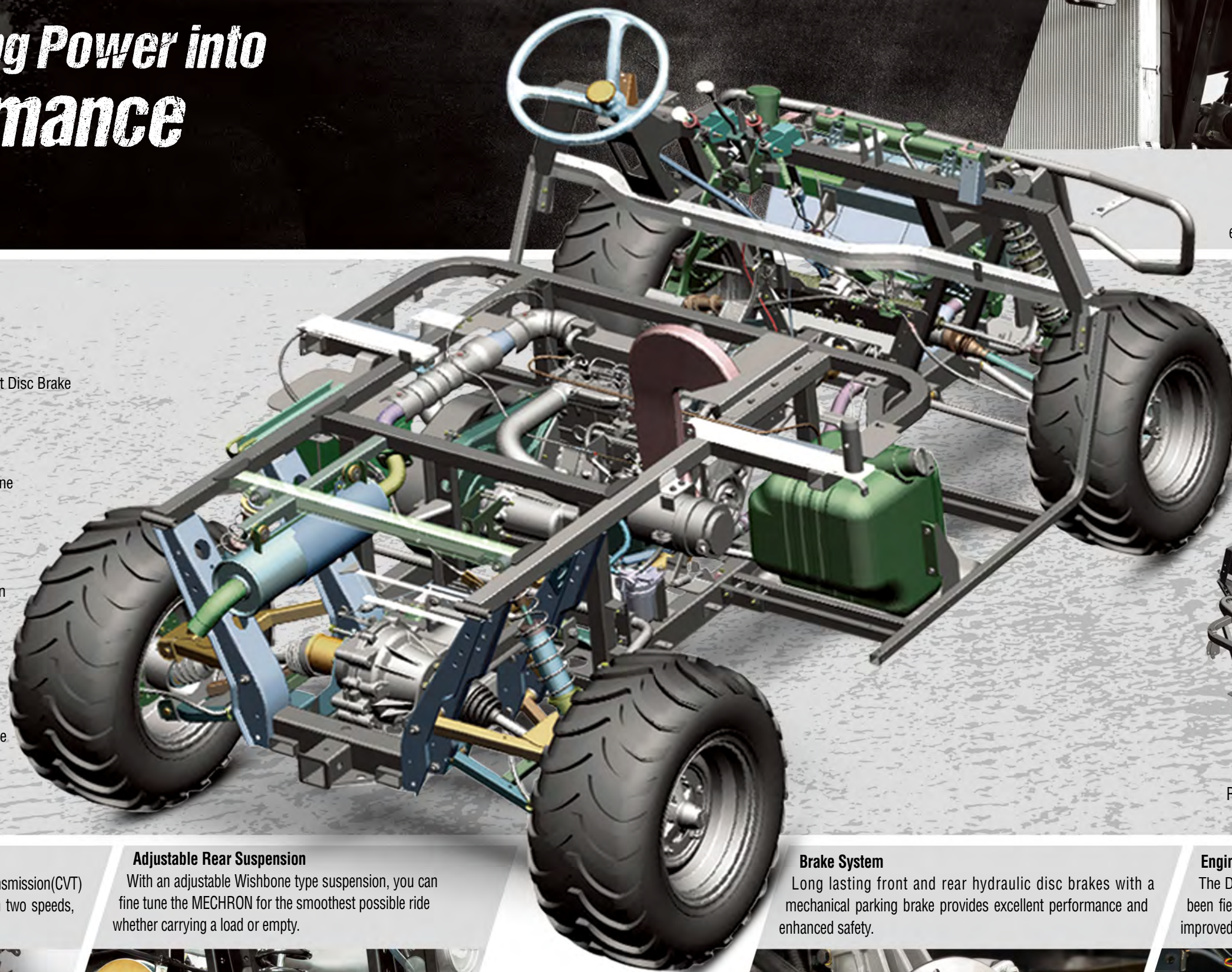
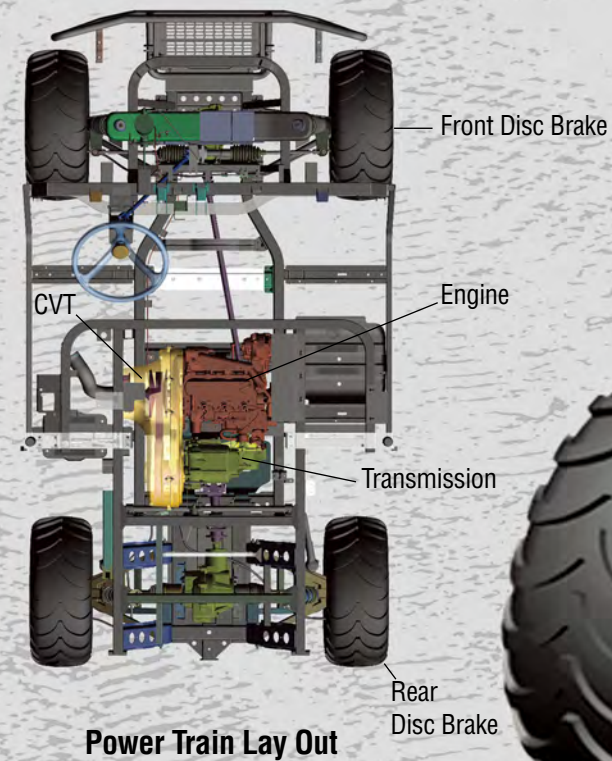

Front Suspension
A MacPherson Strut type suspension ensures the best ride of all the competition while providing the driver excellent road-feel and control.

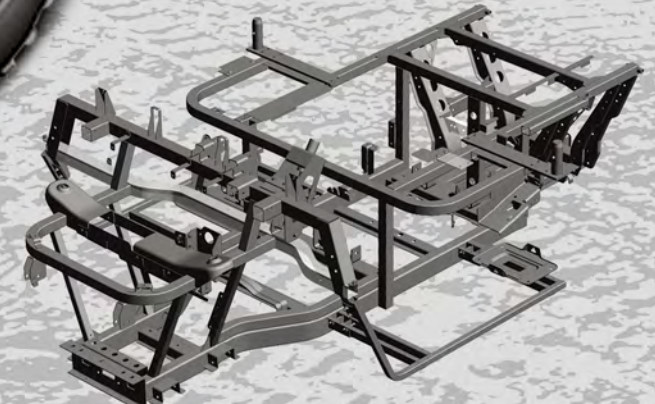

Solid Frame
Robust body frame with strong tubular steel and welded ROPS will protect drivers and passengers.

Transmission
The MECHRON uses a continuously variable transmission(CVT) and has a time proven Daedong gear box with two speeds, (Hi/Lo) and 4WD.

Adjustable Rear Suspension
With an adjustable Wishbone type suspension, you can fine tune the MECHRON for the smoothest possible ride whether carrying a load or empty.

Brake System
Long lasting front and rear hydraulic disc brakes with a mechanical parking brake provides excellent performance and enhanced safety.

Engine
The Daedong 3C100LFU (1007cc, 22HP) diesel engine has been field proven for durability and dependability while offering improved fuel economy.

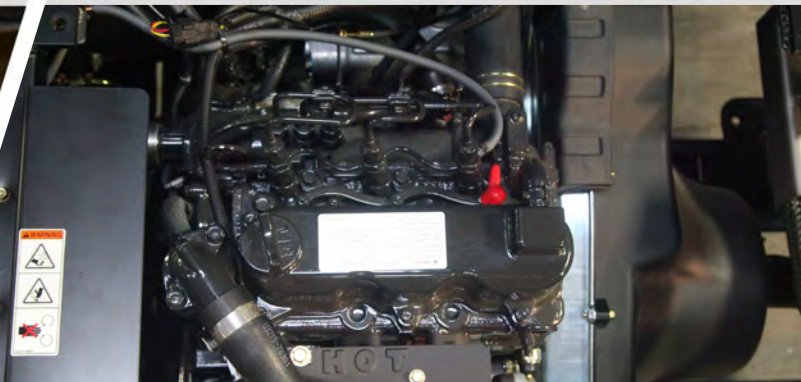
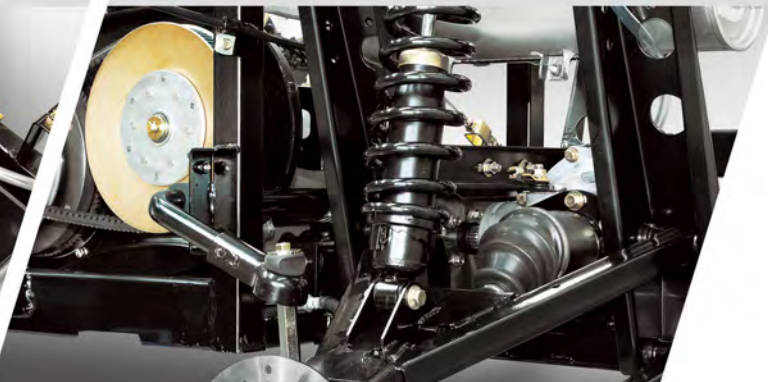
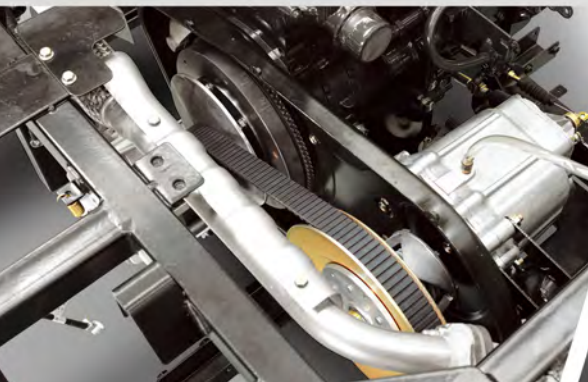



Balancing weight and performance for full payloads

Canopy (Option)

An impact resistant plastic canopy helps to protect the driver and passengers. MEC2200/2210



Hood

The sleek design of the reinforced plastic hood provides a strong and dynamic look. MEC2230/2240



CARGO BED LENGTH 1280mm(300mm longer)
* MECHRON2200/2210 : 980mm

Cargo Bed

With the widest cargo bed in its class and 500kg load capacity, the MECHRON provides excellent payload capabilities. Add the optional hydraulic dump kit and you can easily place any load where you want it. With



Rear Hitch Receiver

A 2-inch rectangular hitch receiver enables you to attach a trailer and receiver equipped implements.



Differential Locks

- Front: Limited Slip Differential
- Rear: Mechanically Actuated Differential Lock





Powerful acceleration with a Daedong Diesel Engine



Rear Fenders

Reinforced, molded rear fenders mounted under the bed deck keep you and your MECHRON clean under the muddiest conditions.



Ground Clearance

Don't get stuck on the trail. With 305mm of ground clearance, you can easily climb over obstacles.



Brush Guard

The heavy duty steel brush guard offers protection for the headlights, radiator, and front differential from rocks, tough brush, and other debris on the trail.



Wheels and Tires

Larger 305mm wheels and 610mm tires provide a smooth ride and more ground clearance.



Shift Levers

An in-line shift makes range selection simple and easy. 4WD selection and rear differential lock are engaged with a single pull knob.



Storage Compartments

An open dash storage area on the driver side is complemented by a closed dash storage area with a water proof lid on the passenger side.



Cup Holders

A cup holder on each side is standard with a removable tray for passenger and driver convenience.



Power, Strength, Agility, and Comfort

*Stretch out on the Wide bench seat
with room for passengers and the driver*

Floor

With a flat walk-thru design, the MECHRON has excellent leg and foot room for easy entry and exit.



2-Row seating of the new MECHRON 2240 provides a comfortable environment for 4 people.

Dash Board

With its cockpit-like looks, the ergonomically located controls and instruments allow the driver to view critical functions at a glance.



Bench Seat(MEC2200/2210)

With a contoured bench seat that is the widest in its class, the MECHRON offers room to seat three comfortably. Three seat belts are standard for safety.



Standard Instrument Cluster

Speedometer in MPH(km/hr), hour meter, fuel gauge, coolant temperature gauge, check engine light and turn signal indicators are standard.

